

EDI DISTRIBUTOR

## QUICK START

# INSTALLATION MANUAL

US PATENT NO. 5,803,695  
OTHER US AND FOREIGN PATENTS PENDING

**V3xx[F][N][D][6] ROMS**  
12/15/2005



Before using this manual please read and understand the warnings and cautions in the Operation Manual to avoid serious personal injury.

This manual describes the wiring and setup for EDI distributors and is a supplement to the EDI Operation Manual.



## **PRE- INSTALLATION QUESTIONS & ANSWERS**

### **What Are the Power Requirements?**

The control requires 120 volt 50/60 Hz control power, .5 amp max., and a motor power supply, usually 230 volt or 480 volt for the 1/2 HP motor with brake. Contact us if you will be using voltages other than these. If the optional cold weather package is used (see below), 115 volt must also be available at the brakemotor.

### **Where Should the Control Be Mounted?**

Most installations place the control at the most convenient location for the operator, often the office, control room or scale room. The control enclosure is NEMA 12 (dust tight) but the display is not weather proof or dust tight. Some dust won't hurt the display but water certainly will. The control enclosure or the display terminal are not rated for placement in a hazardous environment.

### **What Kind of Sensor Wire must Be Used?**

There are 2 sensors for each driven spout on the distributor and each sensor requires 2 wires. These sensors are intrinsically safe so the 4 wires can be as light as 26 ga., unshielded and up to 1000' long. Door bell or thermostat wire is just fine if you are so inclined.

### **Do Sensor Wires Have to Be Run in Conduit?**

There is no electrical reason to put it in conduit but most people do to protect it from mechanical damage. Do not run sensor wires in a conduit with any power wiring.

### **Why Does it Use a Reversing Starter?**

The EDI control uses a reversing motion control even on full round distributors. It's purpose is to not only select the closest path to the newly selected duct but also to back up and re-read the spout location on power up or if there were a reading error. It also eliminates the need for the electrician to check the motor for proper rotation.

### **Can We Use a Different Starter?**

The starter supplied with the control has been tested extensively to operate more than 500,000 cycles while generating only a minimum amount of electrical noise. In addition, keeping the starter in the control box simplifies troubleshooting if it becomes necessary. If the starters are moved to a different location it is advisable to keep them in the same area as the control. We recommend using the starter we supply.

### **What about Cold Weather Operation?**

All drives are filled with Mobil 1 synthetic oil rated for -20°F. If the distributor is installed in an area that is subject to freezing we recommend that the optional motor heater be used. This is a 115v, 25w unit that fits on the back end of the brakemotor and can be left on year around.

### **What Is the Learn Mode Program?**

Only once, at the initial installation, the control must learn certain details about the distributor it is connected to. Information such as the number of ducts, read timing elements and spout centering information must be gathered and put into permanent memory. Most of the information will be obtained automatically but you must enter the spout centering data. This information is saved in battery backed memory.

### **What Happens If Power Is Lost?**

When power is restored, all programmed information is recalled from the battery backed

memory so the setup program doesn't have to be run again. The control/distributor must then be reset from the keypad.

**Can the Display Be Placed in Another Location?**

The display may be removed from the control and placed up to 50' away. We can supply the cable if you wish to do this.

**Can the Distributor Be Controlled from a PLC?**

Yes. Call us for more information.

**--- ALERT ---**

**Using Uninterrupted Power Supplies on EDI Controls**

Uninterrupted Power Supplies (UPS) should not be attached to the EDI control unless certain precautions are taken with the selection and/or wiring of the UPS.

The barrier relay, located in the lower left corner of the control, is powered by the 120 VAC line input. Its function is to provide power to the two sensors in the distributor and condition the return signals. Since the sensors can be located in a hazardous location the relay must provide safe power to them, thus they are more sensitive to extreme input over voltage conditions than other electronic components. The internal fuse in the relay is designed to handle short-term peak voltages up to 350 volts. They will fail when the voltage spikes above this level. The other components in the EDI control do not exhibit this higher sensitivity.

A problem with most low cost UPS systems is that they attempt to replace the normal AC sine wave by outputting a very short term high voltage pulse. We have tested some of these units and have found voltage pulses exceeding 450 volts. Most electronic equipment will try to 'average' this pulse with time so it looks like normal 120 volt power. For safety reasons the barrier relay fuse must blow when it receives these extreme voltages. This fuse is not replaceable.

Another problem with the low cost UPS is that it normally operates offline, passing through the 120 volts it receives, and switches online, to battery backup mode, when there is a power failure. This is when most barrier relays fail because the UPS is trying to over-compensate with high voltage pulses while it changes to online mode.

To eliminate this potential problem, a proper UPS should be selected. Each control requires about 50 VA.

**Specify a UPS that runs continuously online and has a sine wave output.**

It is possible to continue to power the relay from the 120 volt line and use an inexpensive UPS for the rest of the control. Please contact us if you wish to do this or have any questions regarding UPS selection.

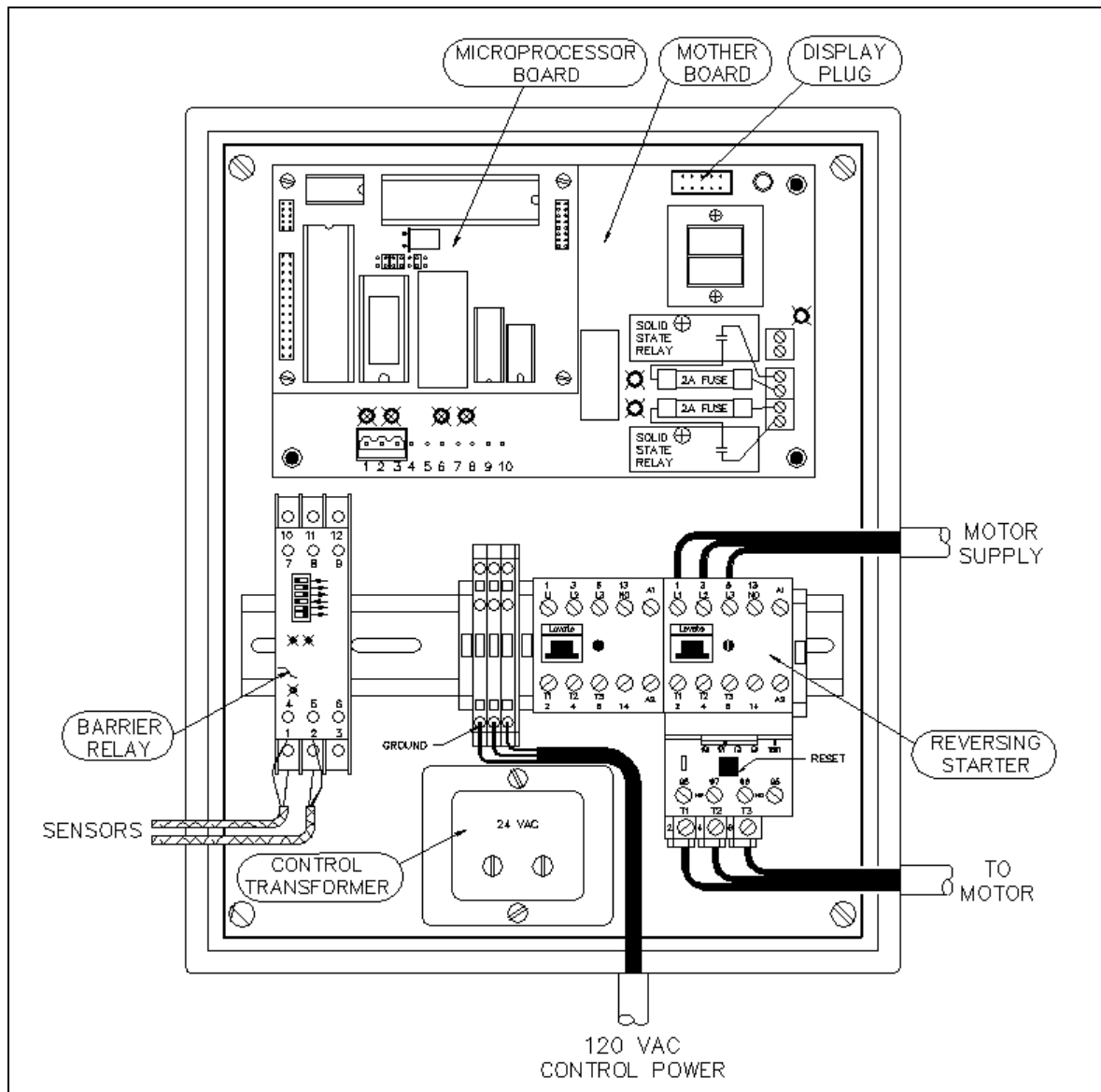

**Figure 1. Control component identification.**

Figure 1 shows the interior of the EDI control. Note the arrangement of the field attached wiring, particularly how it is routed into and out of the control enclosure. **Any high voltage wiring that is looped or routed differently than as shown can cause interference with the electronic components and cause the EDI operation to intermittently fail.**

**Important:**

Do not attach an Uninterrupted Power Supply (UPS) until you have read the Alert at the beginning of this manual.

## WIRING THE CONTROL

Observe Figure 1 and note the location of the wiring. It is very important to keep the high voltage wires away from the electronic components.

### 110 VOLT CONTROL POWER

Place the branch circuit breaker in a close location.

Bring wiring into the 110v terminal strip.

Provide good ground bonding at each end.

#### CHECKOUT

Apply power to the panel.

24 vac lamp must be lit on the right side of the control board.

### 3 PHASE MOTOR CIRCUIT

Most EDI drives use 1/2 HP 3 phase 230/460 volt motors with an electric brake.

**The brake must be wired properly within the motor. The instructions for this wiring is on the motor.**

Special order motors will be indicated on the packing slip.

**Current draw in AMPS for various voltages. (Motor & Brake)**

	115 V 1 Phase	230V 1 Phase	208 V 3 Phase	230V 3 Phase	480V 3 Phase	575V 3 Phase
1 / 2 HP	9.8	4.6	2.0	1.8	0.9	0.8
3/4 HP				2.5	1.25	1.1

Standard overloads are adjustable from .9 to 1.8 amps.

Provide power from a fused disconnect to the starter on terminals **L1,L2,L3**.  
Supply power to the distributor motor from terminals **T1,T2,T3**.

Adjust thermal overload to full motor load current. You may order a different overload if the standard unit does not cover the required amp range.

Make sure reset button is pushed in.

#### CHECKOUT

Manually operate the starter thru either window at the top of the starter. Confirm distributor rotation in both directions. There is no need to check for proper motor direction.

## CONNECTING THE SENSORS

The sensors are part of an intrinsically safe circuit. There are 2 two wire sensors, thus 4 wires required for each drive. Use 26 ga. or heavier, stranded or solid, shielded or unshielded wire up to 1000' in length. (Thermostat wire is fine.) Do not run sensor wires with power wiring. Keep sensor wiring in the lower left side of the control box.

Note: Sensors are polarity sensitive but will not be damaged by a temporary reversal. You can't smoke anything by hooking it up backwards...it just won't work!

Make sure the small switches on the relay are in the proper position.

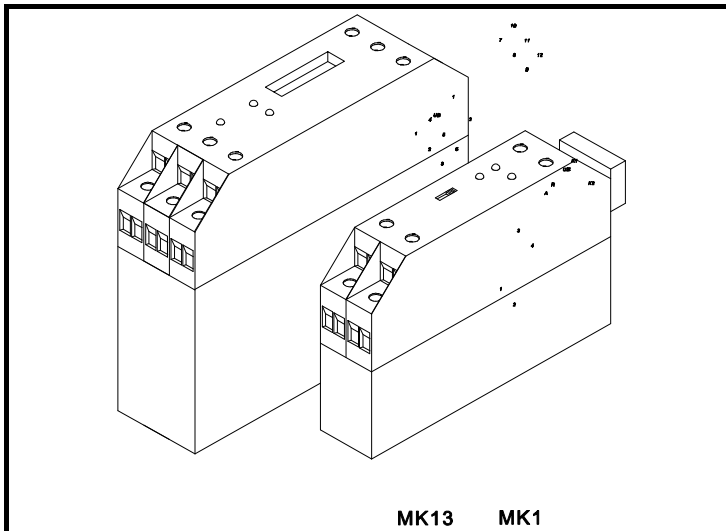

BARRIER RELAY MODEL	SENSOR #1		SENSOR #2		SWITCH SETTING
	BROWN	BLUE	BROWN	BLUE	
MK13	TERMINAL 1	TERMINAL 4	TERMINAL 2	TERMINAL 5	← R/A Ⓡ 1DB Ⓡ K ← R/A Ⓡ 2DB Ⓡ K
MK1	TERMINAL 1	TERMINAL 3	TERMINAL 2	TERMINAL 4	↑ R - A

### CHECKOUT

Apply 110v control power to the panel. At least the green lamp on the relay marked **UB** should light.

There are 2 lamps side-by-side on the relay designated 1 & 2 on the MK13 and K1 & K2 on the MK1. These will be referred to as the left & right lamps for the rest of the procedure. These lamps indicate the switching status of each sensor.

#### **MK13 Relay Only.**

The purpose of this next test is to observe the sensors actually reading the coded information inside the distributor as the spout moves.

Manually engage either side of the starter to start spout motion. If you are installing a flatback or swingset distributor, the spout may be at one end or the other so there may be no motion unless the other side of the starter is engaged.

The **RIGHT** lamp on the relay should blink off rapidly in sets of 5 blinks per burst.

The **LEFT** lamp on the relay should blink off intermittently during each burst.

If the blink pattern is opposite exchange the sensor wiring. Likewise, if one side or the other does not blink, correct the wiring problem before going further.

## INSTALLATION CHECKLIST

---

**Important:**

Be sure the correct ROM is being used for the type of distributor being controlled. The ROM name is located on a chip with a white label on the Microprocessor board. A common mistake in multiple control installations is attempting to control a Full Round distributor with a Flatback ROM. Please refer to the packing list for the correct ROM type.

Before you startup the control, use this checklist to make sure everything is ready.

110 volt control supply is on.

3 phase motor supply is on and fused. It is not necessary to check for proper rotation.

The reset on the starter is set.

The barrier lamps have been checked for the proper blink pattern.

The brake on the motor has been wired and is working. Instructions are usually inside the motor conduit box and on the outside of the motor or brake housing.

The distributor spout has been fully turned and has been checked for free movement.

The sensors are properly spring loaded and shimmed. This should only be necessary if they have been moved from the factory setting.

## LEARN MODE - FULL ROUND DISTRIBUTORS

Display reads:	Your action:	Comment:
RESET=0 NEW=1 or ENTER=RESET  WAIT... COUNT=x	<b>1</b>	Wait while the distributor runs thru an automatic setup sequence that counts the number of ducts.  During this time the display shows the count as each position found on the distributor. When finished, this number must match the actual number of positions on the distributor.  It then moves the spout to duct number 1 for the centering adjustment.
75 ADJ #	<b>100&lt;enter&gt;</b> (Example only)	You now enter numbers from 1 to 1000 or more followed by <enter> until you are satisfied that the spout centers properly. Each time the spout will re-center it self using your new number.  A beginning default centering number of 75 is used by the control. Let's assume it's a little short of centering on the duct.  Spout will re-center itself on duct 1 using 100 as the centering number.
100 ADJ #	<b>90&lt;enter&gt;</b> (Example only)	Now, assume it went a little too far.  Spout will re-center itself once more on duct 1.
90 ADJ #	<b>0&lt;enter&gt;</b>	Looks good.  The '0' tells the control that you're satisfied with the centering for duct 1.
RESET MEMORY 1=YES 2=NO	<b>1</b>	The control will now setup the display with default names & numbers if you press >'1'.  The control stores all this information into permanent memory and does some house keeping chores. The lights on the display will blink as default bin numbers and names are put into memory.
< n> POS n		You're done. Go ahead and use the distributor.  Read the Operation Manual on how to program the control in order to use your custom numbers and names.

## LEARN MODE - FLATBACK OR SWINGSET DISTRIBUTORS

Display reads:	Your action:	Comment
RESET=0 NEW=1 or ENTER=RESET	<b>1</b>	The spout starts in motion. Wait while it runs thru an automatic setup sequence to find duct 1. When the spout stops it is not properly centered. You will adjust this in the next sequence.
200 ADJ #1	<b>400&lt;enter&gt;</b> (Example only)	You can now enter numbers from 1 to 2000 or more followed by <enter> until you are satisfied that it is centered properly. Each time the spout will re-center it self using your new number.  Let's assume it's a little short of centering on the duct. The spout will backup up and re-center itself on duct 1 using 400 as an adjustment number.
400 ADJ #1	<b>350&lt;enter&gt;</b> (Example only)	Now, assume it went a little too far.  The spout will backup up and re-center itself on duct 1 using 350 as an adjustment number.
350 ADJ #1	<b>325&lt;enter&gt;</b> (Example only)	The spout will backup up and re-center itself on duct 1 using 325 as an adjustment number. Let's assume this looks good.
325 ADJ #1	<b>0&lt;enter&gt;</b>	The '0' tells it you're satisfied with the centering for duct 1. The spout will now go into motion searching for the last duct, counting the number of ducts as it moves. When it finds the last duct it will stop and request a centering number while also displaying the last duct number.
75 ADJ #n	<b>90&lt;enter&gt;</b> (Example only)	Proceed as with duct number 1 keeping in mind that the centering number used for the last duct is also automatically used for all other ducts except duct 1. #n = Number of ducts on your distributor.  Keep entering numbers until you are satisfied with the centering.
95 ADJ #n	<b>0&lt;enter&gt;</b>	Looks good.
RESET MEMORY 1=YES 2=NO	<b>1</b>	The control will now setup the display with default names & numbers if you press '>1'.  The control stores all this information into permanent memory and does some house keeping chores. The lights on the display will blink as default bin numbers and names are put into memory.
< n> POS n		You're done. Go ahead and use the distributor.  Read the Operation Manual on how to program the control in order to use your custom numbers and names.

## INSTALLATION TROUBLESHOOTING

### **Before You Call for Help, Please Check the Following:**

Most start up problems occur because the left and right barrier relay lamps are wired improperly or are wired backward (left/right).

Both lamps must blink during spout movement.

The **right** lamp must show a burst of 5 blinks then a quiet period before the 5 blinks repeat.

The **left** lamp must blink intermittently.

As soon as the 'I' key is pressed for the LEARN MODE you should hear the starter pull in. If it doesn't check the reset on the starter overload.

After the starter pulls in you can detect spout motion when the K1, K2 lamps blink. If they both don't blink there may be a problem with:

- the motor supply power
- a mechanical blockage in the path of the spout
- miswired or damaged sensor wiring
- sensors not positioned properly.

More troubleshooting information is presented in the Operation Manual. You may want to refer to this manual to review the operating principles of the EDI distributor.

After checking the above and you have not corrected the problem, please call us for technical support. It is very helpful if you can be at the control with a phone.

## HOW TO CONTACT US

Schlagel, Inc.  
491 No. Emerson St.  
Cambridge MN 55008

Phone: 763-689-5991 800-328-8002  
Fax: 763-689-5310  
E-MAIL: [sales@schlagel.com](mailto:sales@schlagel.com)

Field Service: We have field service personnel covering the entire United States and Canada. Please contact us for details.



**Please contact our service department for help with any  
concerns or questions about your EDI Distributor.**

**SCHLAGEL**

491 North Emerson Street \* Cambridge MN 55008-1316 U.S.A.

Toll Free (800) 328-8002      FAX (763) 689-5310

Local / International (763) 689-5991    EMAIL [sales@schlagel.com](mailto:sales@schlagel.com)

©2005 Schlagel Inc. Rev. B 12/05 Printed in U.S.A.