

# EZ-ROLL™ CONVEYOR

## Installation and Operation Manual

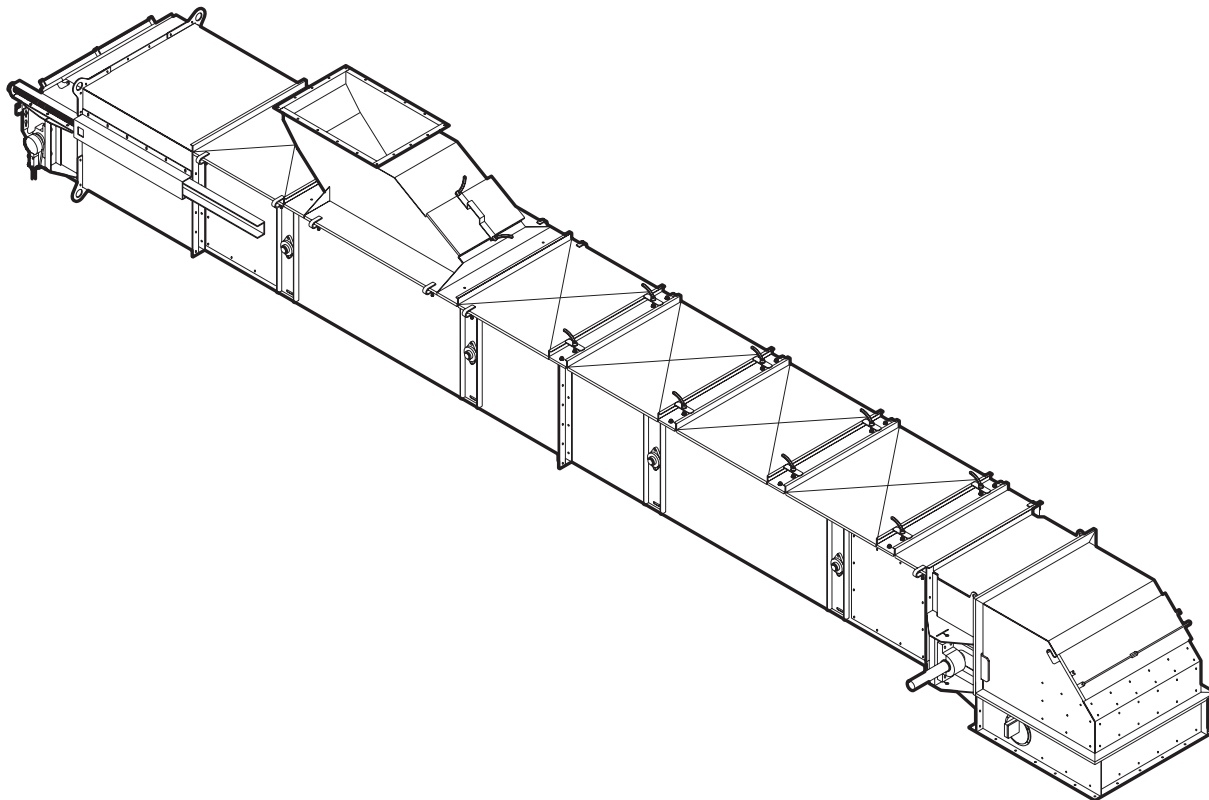

**Enclosed Belt Conveyor**  
Patented

# SCHLAGEL

*Manufacturers of Innovative Materials Handling Equipment since 1957.*

491 North Emerson Street \* Cambridge MN 55008-1316 U.S.A.  
Toll Free (800) 328-8002      FAX (763) 689-5310  
Local / International (763) 689-5991      EMAIL sales@schlagel.com  
**www.schlagel.com**

# TABLE OF CONTENTS

---

## SECTION 1 - GENERAL

<b>Pages</b>	1 . . . . .	Introduction
	1 . . . . .	Use of Manual
	2 . . . . .	Information Service
	2 . . . . .	Uncrating and Inspection
	2 . . . . .	Safety Code
	3-4 . . . . .	Features and Benefits

## SECTION 2 - ASSEMBLY AND INSTALLATION

<b>Pages</b>	5 . . . . .	Conveyor Selection
	5 . . . . .	Installation Preparation
	6 . . . . .	Typical Parts List
	6 . . . . .	Standard Head Section
	6 . . . . .	Standard Tail Section
	7 . . . . .	Trough Sections
	7 . . . . .	Trough Cover Assembly
	8 . . . . .	Inlets
	8-9 . . . . .	Skirting
	10-12 . . . . .	Belt and Splicing
	13-14 . . . . .	Switches & Wiring
	15 . . . . .	Motor, Belt & Drive Tracking
	15 . . . . .	Test and Finishing

## SECTION 3 - OPERATION AND MAINTENANCE

<b>Pages</b>	16 . . . . .	Operation/Maintenance
	16 . . . . .	Trouble Shooting
	17-18 . . . . .	Notes

## INTRODUCTION

---

Schlagel, Inc. has had many years of experience in producing industrial quality material handling equipment.

This conveyor has been designed to give you many years of faithful service. To obtain all of the benefits built in to it, the following instructions should be read and adhered to as closely as possible during installation. These instructions are suggestions to help the contractor determine the best way to install the unit.

All Equipment manufactured by Schlagel is guaranteed to be free from defects in materials and workmanship, providing no alteration or repair has been made by the user unless authorized in writing by Schlagel, Inc.

## USE OF MANUAL

---

This manual provides installation, operation, service recommendations and replacement parts identification for Schlagel EZ-Roll Conveyor.

Each section of the manual is fully illustrated for fast, accurate reference. It is highly recommended that this manual be read thoroughly by those who are responsible for the installation, operation and maintenance of this conveyor. Refer to the Table of Contents for the location of specific information.

As new information and equipment become available, service and parts bulletins will be issued by us. So that they will be readily available for reference, all bulletins should be inserted with this manual. This manual covers standard conveyor equipment only. For any items or special equipment not covered in this manual, please consult our service department for recommendations or instructions regarding this equipment.

**INFORMATION SERVICE**

Our service department will provide consultation on installation, operation and maintenance at no cost to you. Also, information from you, regarding operation or service problems that are not covered in this manual will be greatly appreciated.

Contact us for information on adding new equipment to your system or changing your installation such as: Lengthening or shortening troughs, adding or deleting inlets and discharges, horsepower and speed requirements, etc.

We keep a complete record of each customer's order. However, valuable time can be saved if the information below is provided with your inquiry. It is suggested that you obtain the model number and serial number from the Packing Slip, or on the discharge terminal end of the conveyor, and enter it below for **each** conveyor in your system.

Date of Purchase \_\_\_\_\_

Model No. \_\_\_\_\_ Serial No. \_\_\_\_\_

\_\_\_\_\_

\_\_\_\_\_

\_\_\_\_\_

Email or Call: Schlagel, Inc.  
 491 North Emerson Street  
 Cambridge, MN 55008  
 (763) 689-5991 or 1-800-328-8002  
 sales@schlagel.com

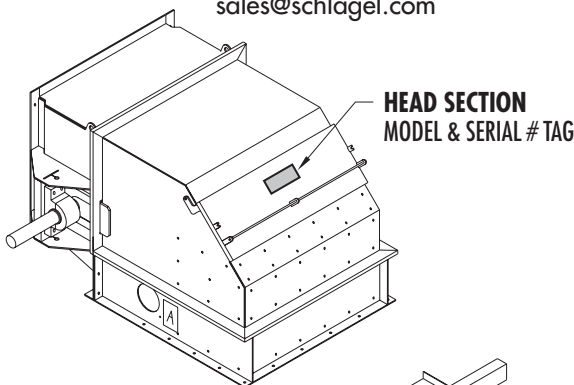

**TAIL TAKEUP SECTION**  
 MODEL & SERIAL # TAG

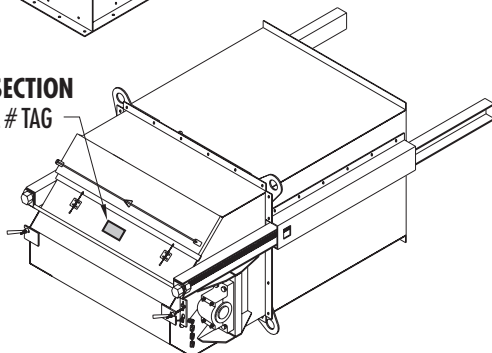

**UNCRATING AND INSPECTION**

Your conveyor has been carefully checked and packed for shipment from our factory. In the event that any parts are missing or damaged, please notify us immediately and also have the delivering carrier note this is on the Bill of Lading.

**IMPORTANT**

*All claims for shipping damages must be noted by the consignee at the time of delivery and filed with the transportation company.*

**SAFETY CODE**

**⚠ CAUTION ⚠**

The icon shown below was proposed as a safety alert symbol by the Farm and Industrial Equipment Institute (FIEI) and approved by the American Society of Automotive Engineers (ASAE) and others for the purpose of calling attention to safety precautions which if not heeded might lead to bodily injury.

*Please read instructions carefully and follow the instructions exactly wherever this symbol appears in the manual.*

**⚠**

**⚠ WARNING**

Moving belt and pulleys can cause severe injury

**LOCK OUT POWER**  
 Before removing covers or servicing

**⚠ WARNING ⚠**

EXPOSED BELT CHAIN & MOVING PARTS CAN CAUSE SEVERE INJURY

LOCK OUT POWER BEFORE REMOVING GUARD

**⚠ WARNING**

Walking or standing on Conveyor Covers or Gratings can cause Serious Injury or Death

**STAY OFF**

### STANDARD FEATURES AND OPTIONS

---

#### HEAD SECTION

- The motor mount, drive mount, bearings, shaft and head pulley are mounted to a heavily reinforced, independent drive frame. The head pulley and shaft can be removed without structural disassembly. The discharge, hood and first trough section all bolt to this frame.
- Lagged head pulley.
- The hood has a full width inspection door and the entire hood is easily removed for access and troubleshooting.
- All discharges are urethane lined and have provision for plug switches on both sides.
- Fully adjustable and shimmed head shaft bearings.

#### TAIL SECTION

- Two screw takeup tail with 24" adjustment screws are accessed from the back and allow for 360 degree wrench swing. No steel to steel contact in any of the takeup mechanism. Support arms slide in UHMW guides. Oversize acme takeup screws are plated for rust resistance and run in a relubricateable brass nut.

**NOTE: A longer takeup adjustment may be necessary for conveyors of substantial length.**

- An effective reload apparatus is incorporated to bring spilled material back to the loaded side of the belt.
- Self cleaning tail pulley.
- The tail pulley and shaft can be removed without structural disassembly.
- A chained drop down door exposes the lower tail pulley area for inspection.
- A full width inspection door allows viewing of belt tracking and the reload area.
- Fully adjustable and shimmed tail shaft bearings.

#### TROUGH SECTION

- Trough bottom is lined with segments of Anti-Static UHMW. This minimizes contact with the return belt to help prevent freeze down. It uses our EZ-Glide system for mounting the UHMW to allow for movement due to thermal expansion and contraction.
- 'Toolless' removal of the idler roller stub shafts.
- Large inspection doors located at each side of the troughs adjacent to the head and tail section.
- Continuous skirting is used when there are multiple inlets.
- Provision for adjusting tracking at the idler pulleys.

#### MISCELLANEOUS

- Painted or galvanized construction is available.
- Capacities beyond 60,000 BPH.

FEATURES AND BENEFITS

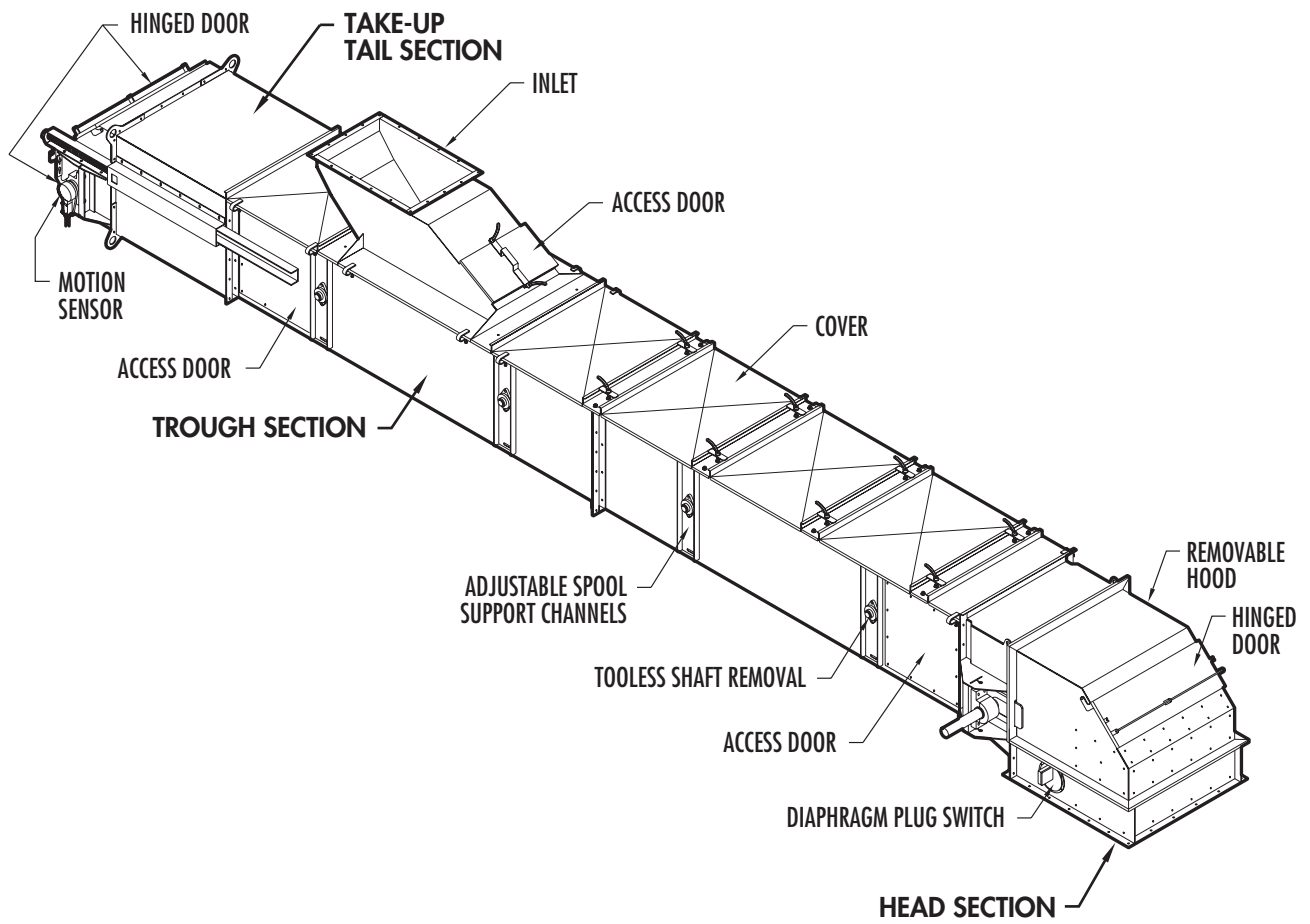

**CONVEYOR SELECTION**

The EZ-Roll Conveyor engineering and selection was completed prior to manufacturing and shipping, but it may be helpful to review the capacities and sizes of standard conveyors prior to installation.

*Specific information must be obtained from the Schlagel Shipping Order, any drawings provided by us, drawings from other sources and manufacturers and information for drives and bearings.*

**Any questions you may have should be resolved prior to the start of the installation.**

**INSTALLATION PREPARATION**

Many issues need to be considered prior to installation. Each site will have unique requirements and many of the special requirements should have been worked out during the ordering process. Here are some of the more important points to think about before starting the installation.

**DRIVE MOUNTING** - Consider yourself sitting on top of the conveyor facing forward.

Should the drive be mounted on the right or left side?

Is the mounting structure adequate to support the entire weight of a fully loaded conveyor and the torque of the drive assembly?

**CLEARANCES** - You must be able to gain access to the top of the conveyor to remove covers, splice the belt, remove and install spool pulleys, clear plugs and general inspection of belt tracking and material loading.

Side clearance allowance must be considered for access to head and tail bearings and bearing adjustment screws as well as stub shafts and bearings for the spool pulleys. Check for clearance below the tail to operate the drop door, the back of the tail to allow for wrench swing, full extension of the telescoping section when adjusting belt tension and, of course, enough room to open, and view through, the tail inspection door.

**EZ-ROLL CONVEYOR - SIZE SELECTION\***

MODEL BELT WIDTH	MAX BPH	TAKEUP LENGTH	MAX RPM	MAX FPM
18	5000	24"	112	500
24	10800	24"	135	600
30	21700	24"	157	700
36	34000	24"	180	800
42	40000	24"	180	800
48	53600	24"	180	800
54	65600	24"	180	800

\*Subject to change without notice.

**INCLINES** - Do not exceed the design incline without first checking with us. If the conveyor was not designed for an incline, or the incline must be increased, several calculations must be made to check for design horsepower, material characteristics, and belt speed.

**INLETS** - Properly directing the material flow into the conveyor is necessary to obtain the design capacity of the conveyor. The belt must accelerate the material toward the discharge in a very short period of time so the spout and inlet design must assist this acceleration. A poor design here can doom the conveyor performance.

If multiple inlets are to be installed there must be an understanding as to how each will be used; standalone or as a controlled inlet to a partially loaded belt. Length and placement of the skirting is also important.

**Inlets near the tail section must be located no closer to the tail than shown in the this chart.**

MODEL	A
18	75"
24	75"
30	76"
36	76"
42	76"
48	76"
54	76"

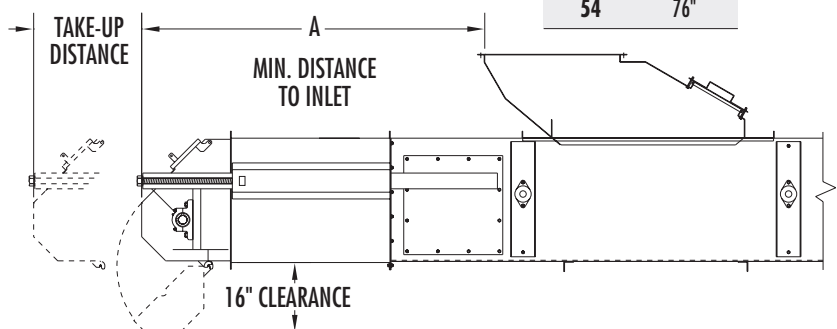

**TYPICAL PARTS LIST**

A typical shipment consists of the following parts:

- Head section with discharge and hood
- Trough section attached to head section
- Takeup tail section
- Trough section attached to takeup section
- Intermediate trough sections
- Cover assemblies
- Inlet assemblies when ordered
- Skirting when needed.
- Belt
- Assembly hardware including belt splice.
- Drive and motor when ordered from us.

**STANDARD HEAD SECTION**

The head section in particular must be securely mounted to transfer any torque from the drive to the mounting structure. Troughs and tail sections should be fastened to the structure at every flange joint.

If it becomes necessary to change the drive shaft from one side to the other, remove the hood and bearing bolts and the entire assembly with pulley can be removed and replaced in one piece.

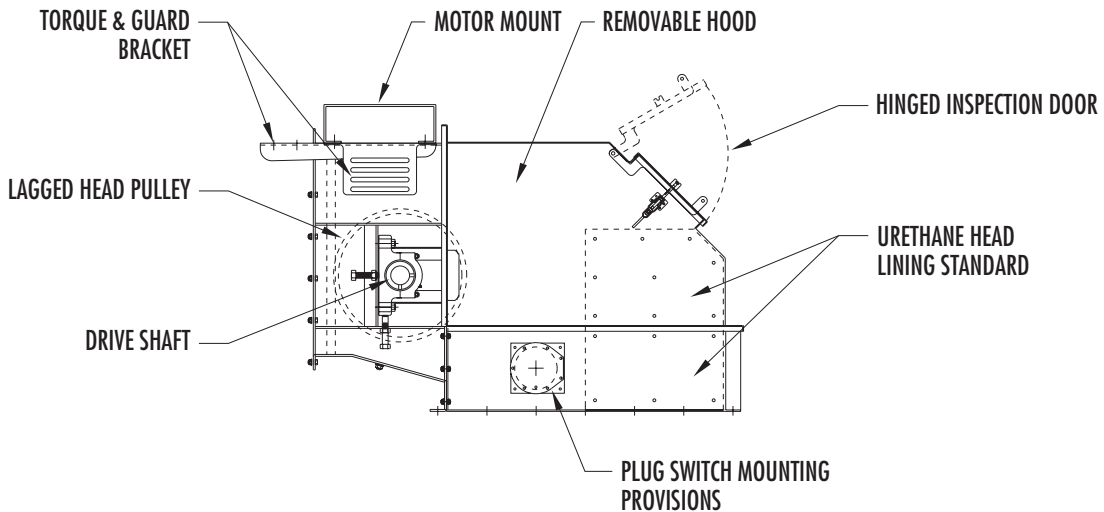

**STANDARD TAIL SECTION**

Check the plow in the tail section to make sure it is properly retained in its mounting.

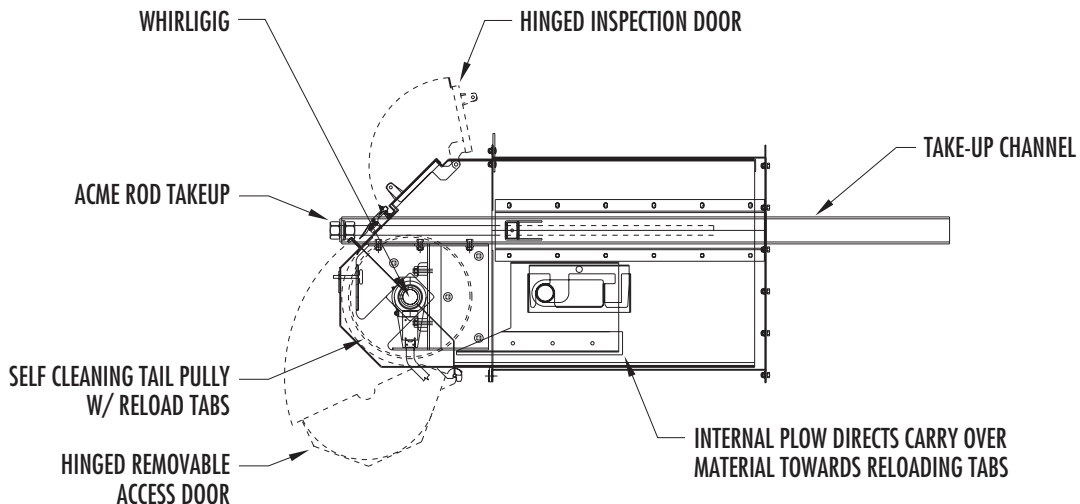

## SECTION 2 - ASSEMBLY AND INSTALLATION

### TROUGH SECTIONS

It is important that the head and tail sections have the correct trough sections attached to them and oriented in the proper direction.

### TROUGH ASSEMBLY

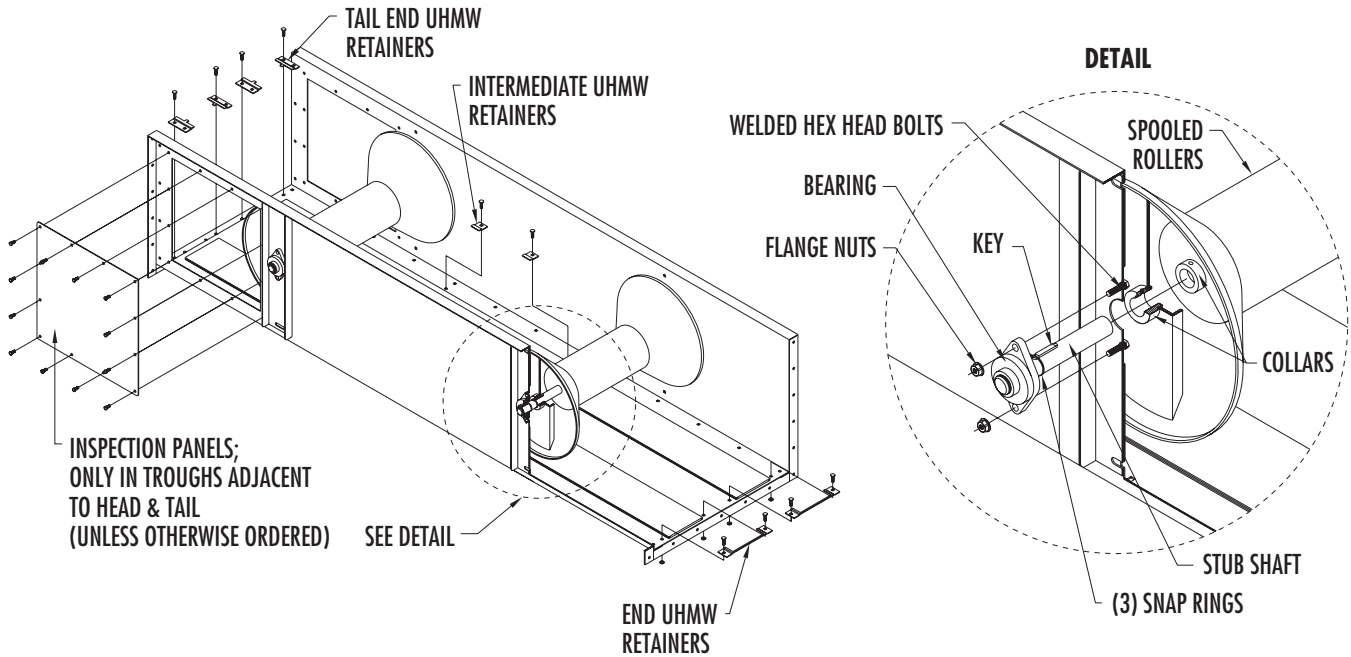

### COVER ASSEMBLY

**NOTE:**

ALL COVER CHANNELS GET SKIRT CLAMPS WHETHER THE TROUGH GETS SKIRTING OR NOT.

**NOTE:**

WILL NEED TO DRILL HOLE IN TROUGH FLANGE TO BOLT COVER CHANNEL IN PLACE.

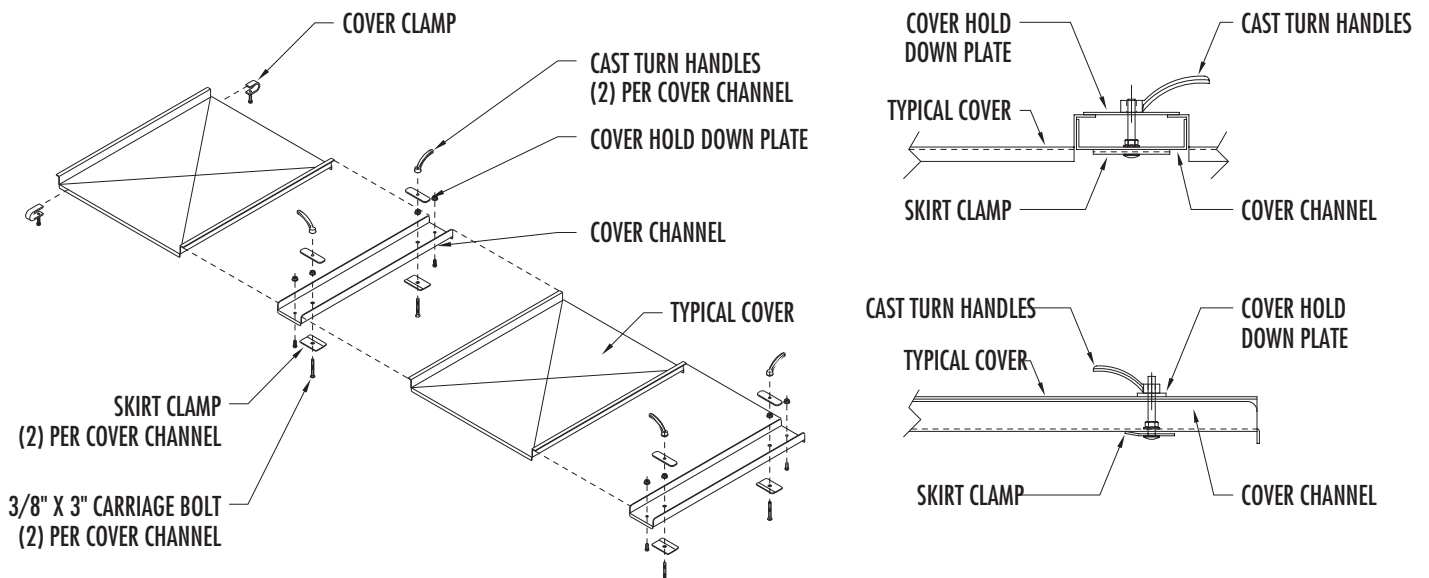

**INLETS**

Mount the inlet(s) and inlet spouting. When spouting the inlets it is imperative that the material is directed so that it will slide along the back side of the inlet and be directed forward as it contacts the belt.

If a gate is used it must be arranged so that it opens from the back side of the inlet first. Also be sure the material impacts the center of the belt and does not try to push the belt to the side of the trough.

**STARTER COVER & INLET INSTALLATION**

INSTALL STARTER COVER TO TROUGH & FASTEN TO TROUGH W/COVER CLAMPS.  
(29 1/4" COVER W/ STANDARD INLET LOCATION)

SET INLET W/ SKIRTING ATTACHED ON TROUGH & SLIDE UP TO STARTER COVER. FASTEN INLET TO TROUGH W/ (4) COVER CLAMPS.

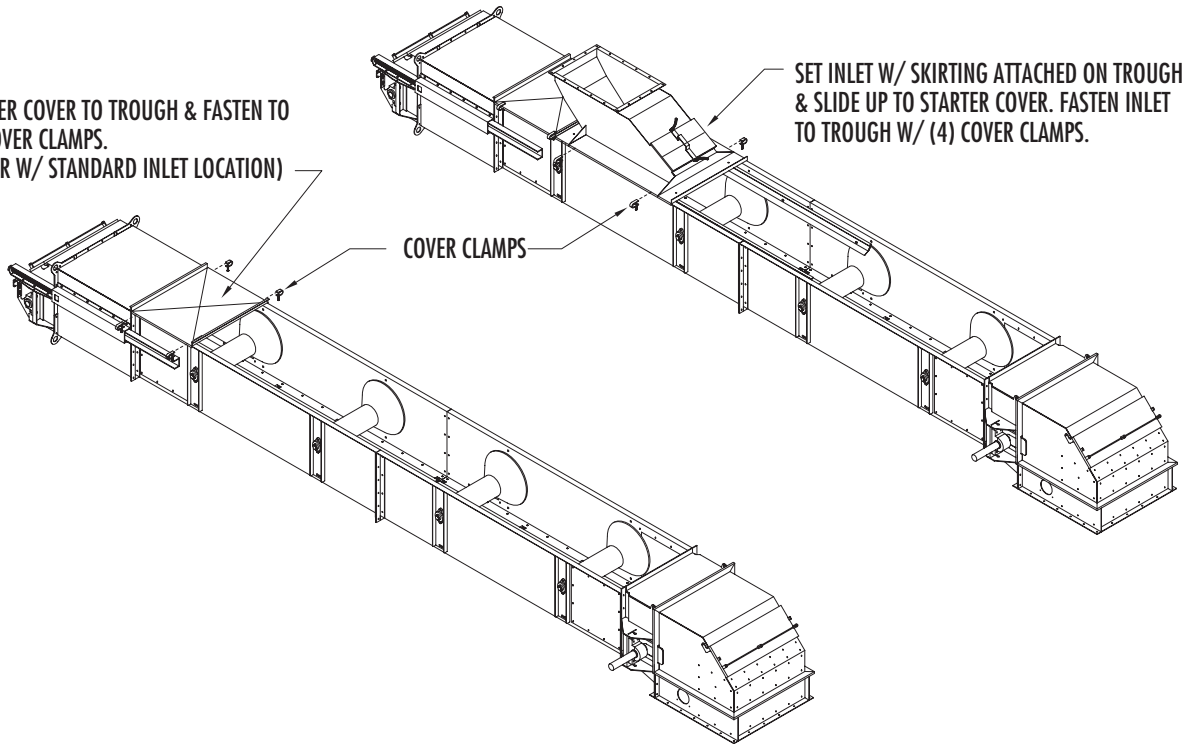

**INLET SKIRTING INSTALLATION**

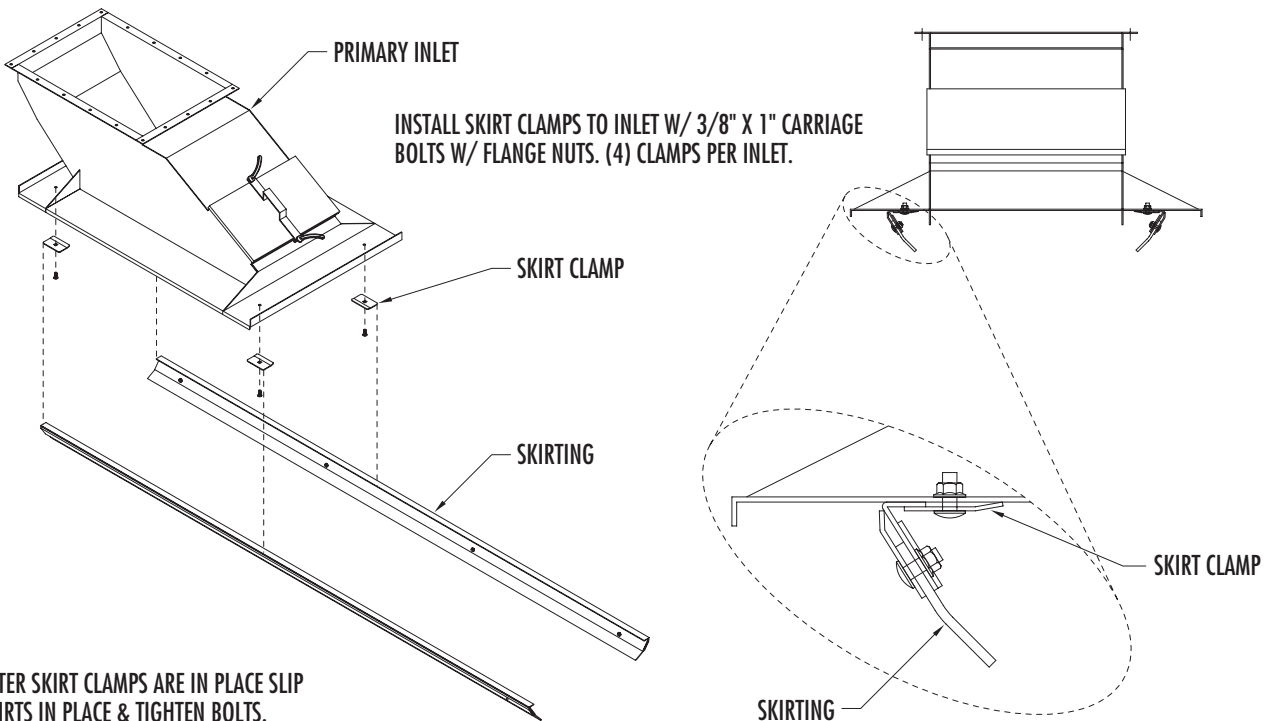

AFTER SKIRT CLAMPS ARE IN PLACE SLIP SKIRTS IN PLACE & TIGHTEN BOLTS.

**SKIRTING**

Skirting is usually needed to concentrate the material, at load time, to the center of the belt, not allowing it to spill over the sides.

When a single inlet is used it is necessary to start the skirt a couple of feet behind the inlet and the same amount forward. This is determined by the distance required for the material to accelerate to belt speed and settle to en-masse movement.

If multiple inlets are required the skirt must be installed as if they were one long inlet. It must start a couple of feet behind the first inlet and the same amount forward of the last inlet.

The skirting is clamped at each inlet and is adjusted to fit against the belt. When using multiple inlets use the cover support channels, spaced to fit the cover, when mounting the skirting. Use the skirt splice plates when assembling multiple lengths of skirting as shown in Figure 1.

Figure 1

**NOTE:** If belt conveyor has more than one set of skirting, then a skirt splice is required. To install skirt splice, remove the nut from the end of the skirting and install splice plate, put the nut back on and tighten after skirting is lined up. Clamp skirting to cover channels wherever possible before all covers are tightened down.

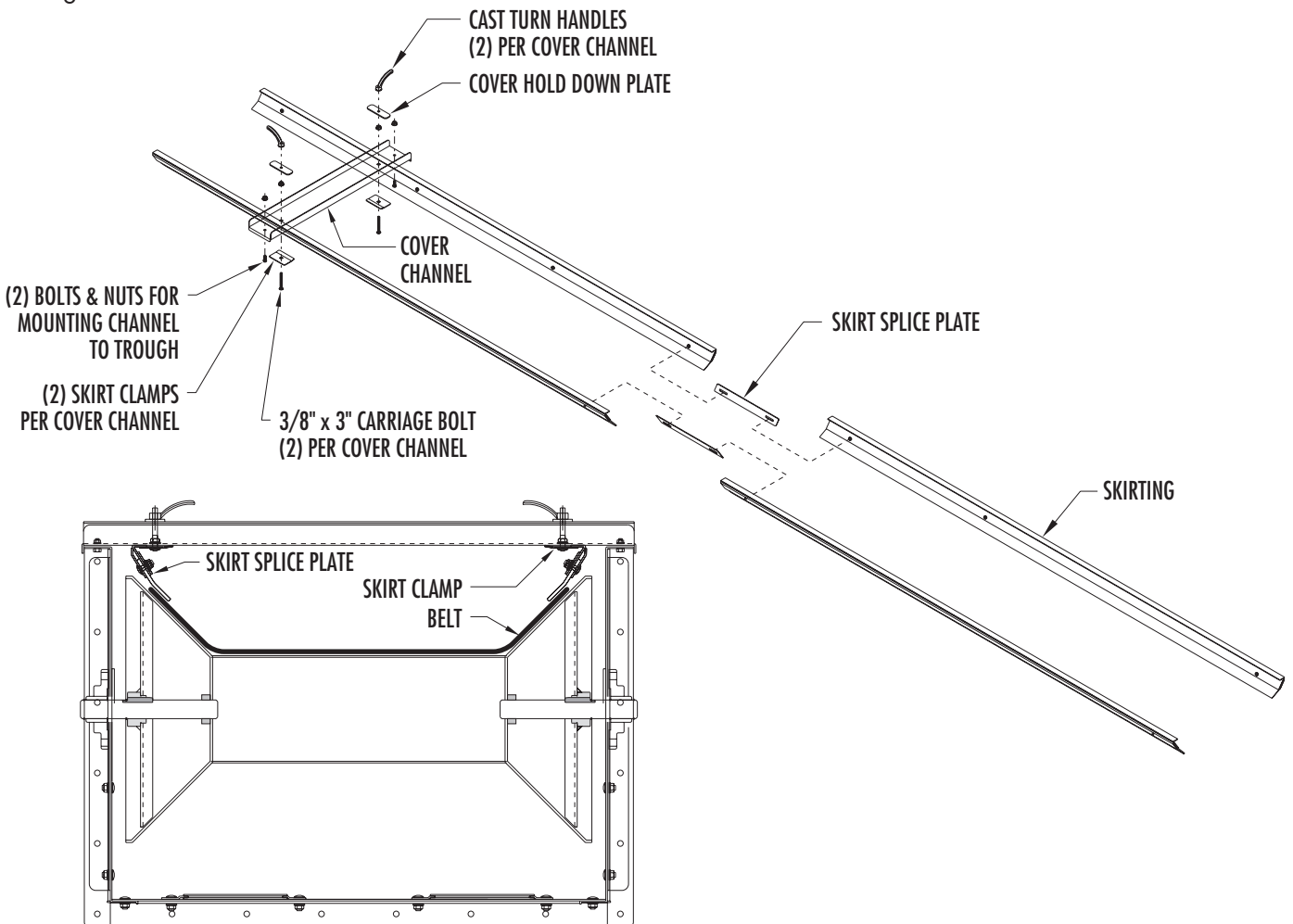

## BELT AND SPLICING

Install the belt making sure it is cut square as shown in Figure 2. Splice it with the included fasteners, as shown in Figure 3, using the manufacturers directions. Then install the splice protection pieces on the leading side of the splice.

### IMPORTANT

*Tensioning requirements vary depending on the length of the conveyor and the belt may need to be re-spliced after it stretches.*

## INSTRUCTIONS FOR CUTTING BELT SQUARE

The following steps will help ensure that your belt is properly squared.

1. Prior to any work on your conveyors, make certain that the power has been turned off and the belt is "locked out." Follow other safety precautions outlined in the operator's manual.
2. Mark the actual center points in belt width at intervals of 3 to 5 feet, for a distance back from the intended splice area of 15 to 20 feet.
3. Using either a steel rule or chalk line, mark the average center line through the points measured from Step 2.
4. Using a square, draw a line perpendicular to your average center line across the belt width.
5. For even greater accuracy in preparing your squaring line and with belts with worn edges, after completion of step three, mark two lines (B & C) equal distance from the center line in the area where you are going to install the splice, running parallel to the center line.
6. Measure back from the intended splice area a distance equal to approximately three times the belt width and drive a nail or awl at this point on the center line. Using the nail or awl as a pivot point, swing an arc, making the belt across the full width.
7. Where this arc intersects the two smaller lines marked parallel to the average belt center, align a steel rule through these points. The resulting line is the true square.
8. Mark this line and cut your belt at this line using a sharp knife or, preferably a belt cutter.

Figure 2

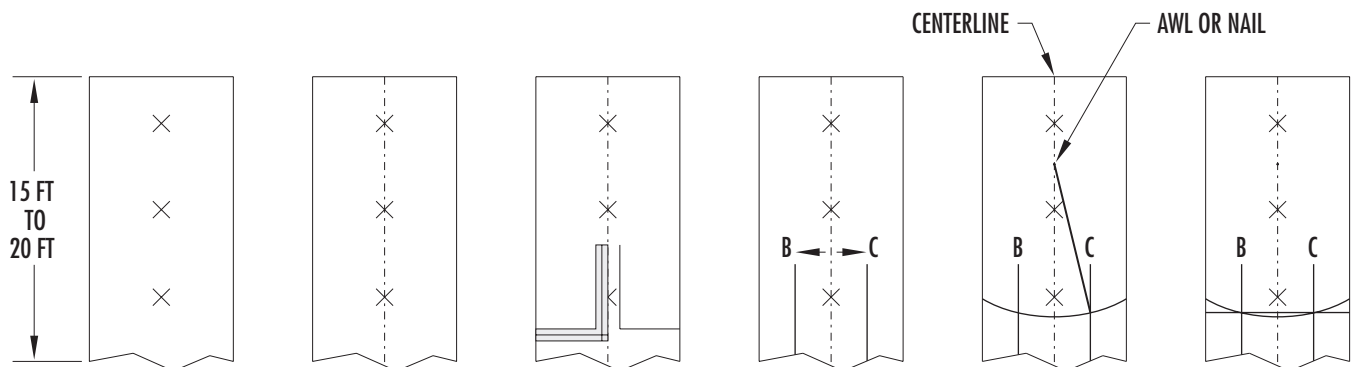

## SECTION 2 - ASSEMBLY AND INSTALLATION

### SPLICE KIT COMPONENTS

Each splice kit consists of Flexco (non-sparking) belt splice fasteners, hole template, Flexco-lok tape, splice protector template, splice protector belt pieces, Flexco bolts and nuts with cupped washers for splice protectors, nails, and hand tools. There is also an optional powertool kit available. For assembly procedures, please refer to instruction sheets packed with each kit.

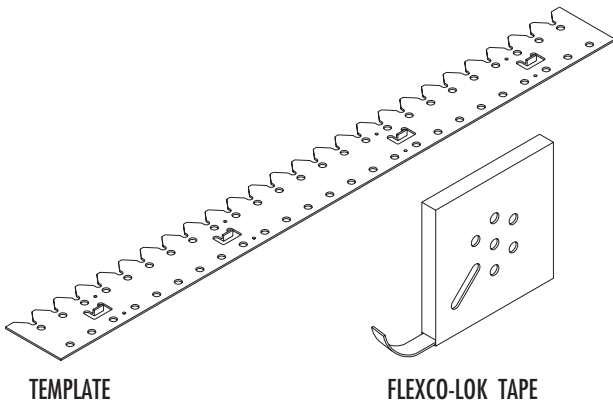

TEMPLATE

FLEXCO-LOK TAPE

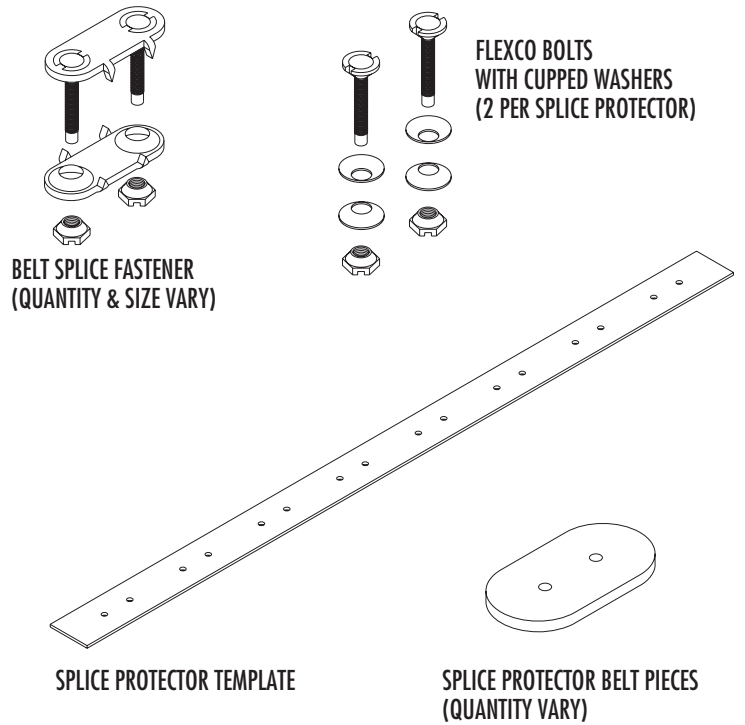

BELT SPLICE FASTENER  
(QUANTITY & SIZE VARY)

FLEXCO BOLTS  
WITH CUPPED WASHERS  
(2 PER SPLICE PROTECTOR)

SPLICE PROTECTOR TEMPLATE

SPLICE PROTECTOR BELT PIECES  
(QUANTITY VARY)

### STANDARD HAND TOOLS

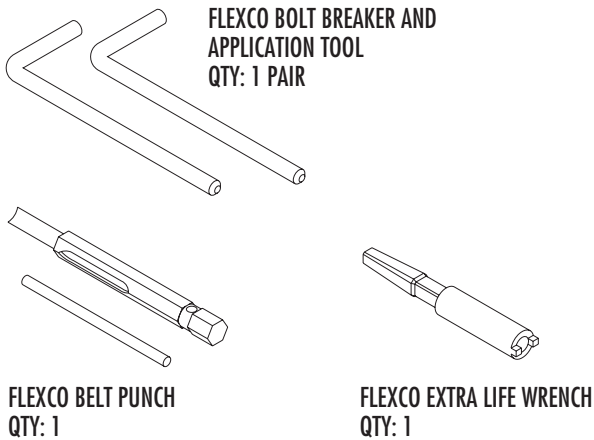

FLEXCO BOLT BREAKER AND  
APPLICATION TOOL  
QTY: 1 PAIR

FLEXCO BELT PUNCH  
QTY: 1

FLEXCO EXTRA LIFE WRENCH  
QTY: 1

### OPTIONAL POWER TOOLS

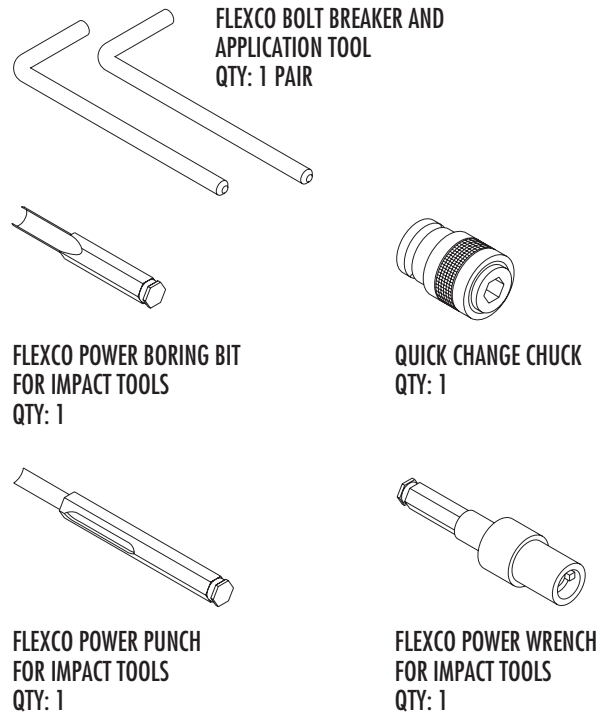

FLEXCO BOLT BREAKER AND  
APPLICATION TOOL  
QTY: 1 PAIR

FLEXCO POWER BORING BIT  
FOR IMPACT TOOLS  
QTY: 1

QUICK CHANGE CHUCK  
QTY: 1

FLEXCO POWER PUNCH  
FOR IMPACT TOOLS  
QTY: 1

FLEXCO POWER WRENCH  
FOR IMPACT TOOLS  
QTY: 1

Figure 3

**BELT SPLICE DETAIL**

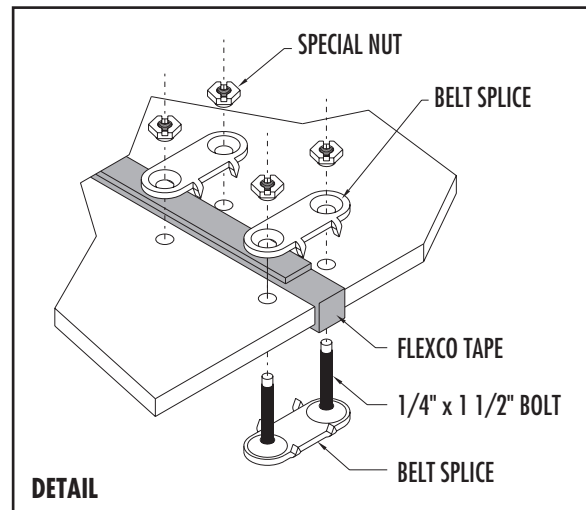
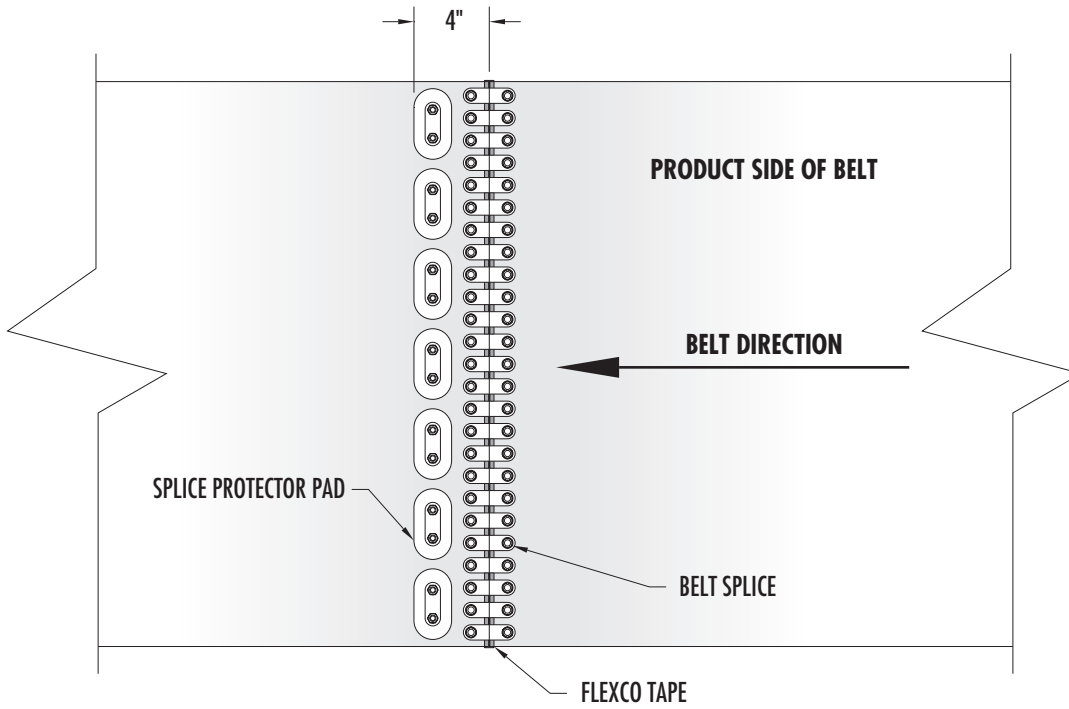

**DETAILED ASSEMBLY**

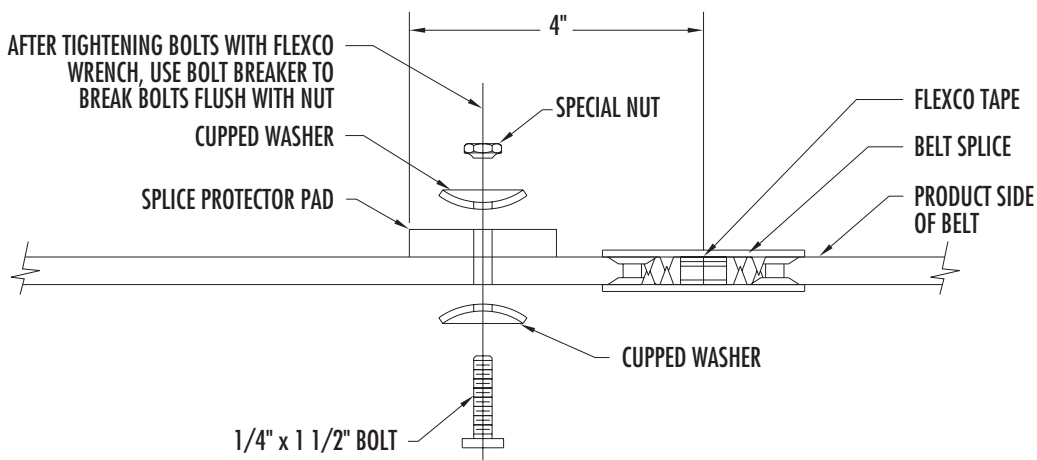

WHIRLIGIG AND M800 ELITE SPEED SWITCH  
MOUNTING INSTRUCTIONS

**! WARNING !**

Do not attempt to mount or service speed sensors and plug switches with conveyor running and covers removed. Shut off and lock the line switch.

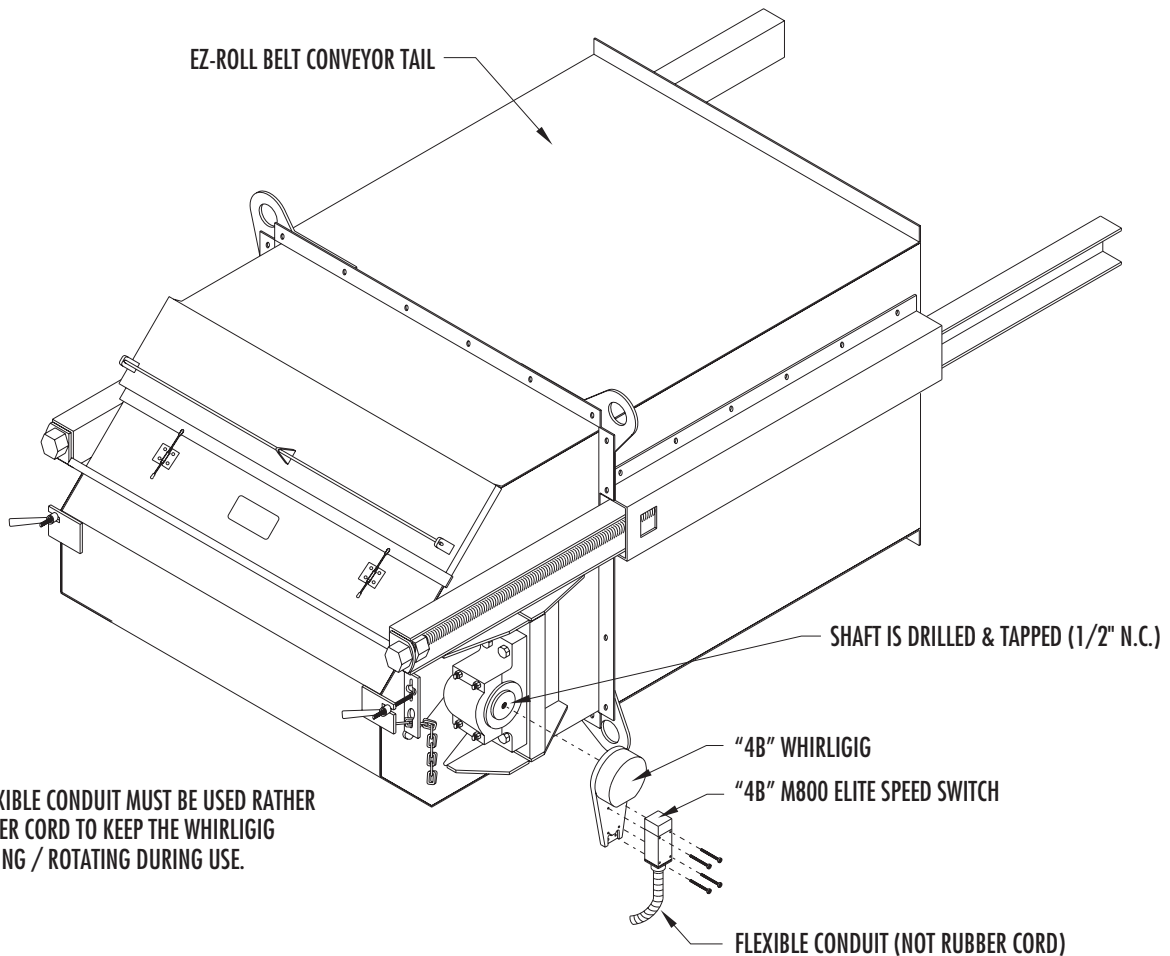

**NOTE:** A FLEXIBLE CONDUIT MUST BE USED RATHER THAN A RUBBER CORD TO KEEP THE WHIRLIGIG FROM SWINGING / ROTATING DURING USE.

INSTALLATION INSTRUCTIONS

1. Thread the Whirligig onto the conveyor shaft using wrench and suitable thread locking adhesive (Loctite or similar).

**NOTE:** The tail shaft has already been drilled and tapped on both sides for ease of installation on either side.

2. Bolt the M800 Elite speed switch to the Whirligig base using the provided bolts. Be sure to leave approximately 2mm between the sensor face and the cover.

3. Wire the sensor by following the manufactures instructions and according to local electrical codes and OSHA regulations.

4. The suggested flexible conduit should keep Whirligig from turning. If conduit is not used, it will be necessary to attach the flexible strap to the conveyor.

**NOTE:** The M800 speed switch and system function can be tested by placing a thin metal plate between the sensor and the cover of the Whirligig.

**M800 ELITE SPEED SWITCH WIRING DIAGRAM**

The drawing below shows the state of the internal contacts when power is applied. The switch can be wired to an alarm so that when the speed drops more than 10% of the set speed the alarm will sound. The shutdown contacts open when the speed drops below 20% of the set speed. For speed calibration and onsite wiring procedures, refer to the manufacturer's instructions packed with the sensor.

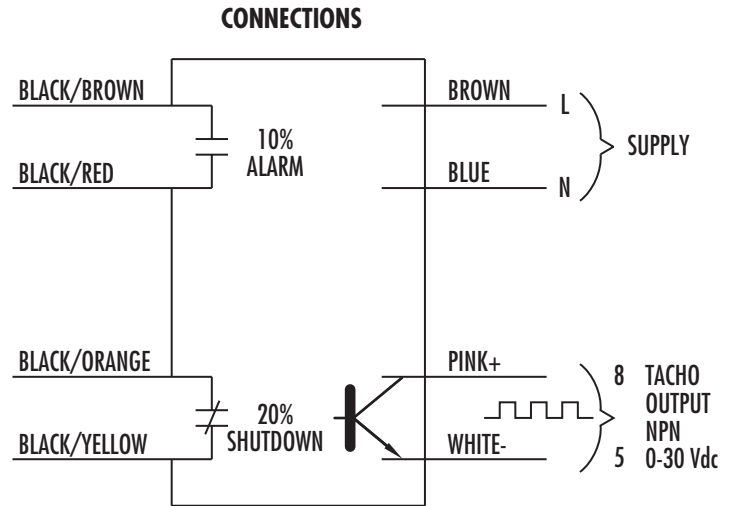

**#7-8150 DIAPHRAGM SWITCH INSTALLATION AND WIRING INSTRUCTIONS**

There are mounting holes precut in the EZ-Roll conveyor head section. The switch can be mounted on either side of the head section. To mount your diaphragm plug switch, simply line up the switch flange with with the cut out in the the head. Be sure to use the supplied gasket between the head section and the sensor flange. Also for best sensing performance be sure to mount the diaphragm switch with the switchcase in the uppermost position. Using the supplied #10 bolts and nuts, mount the diaphragm switch to the head section, making sure to squeeze the gasket thus creating a good seal.

**EZ-ROLL BELT CONVEYOR HEAD**

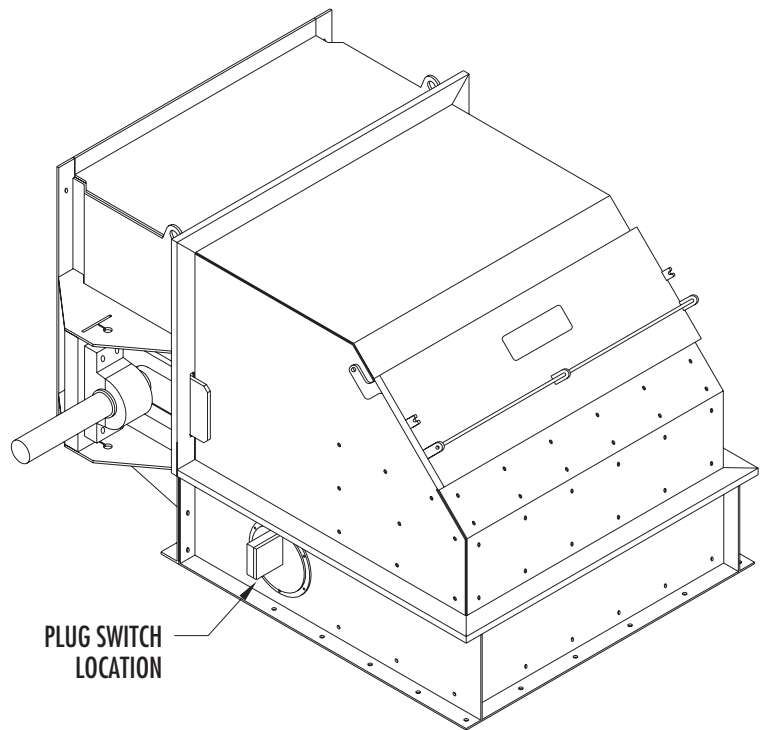

**WIRING DIAGRAM**

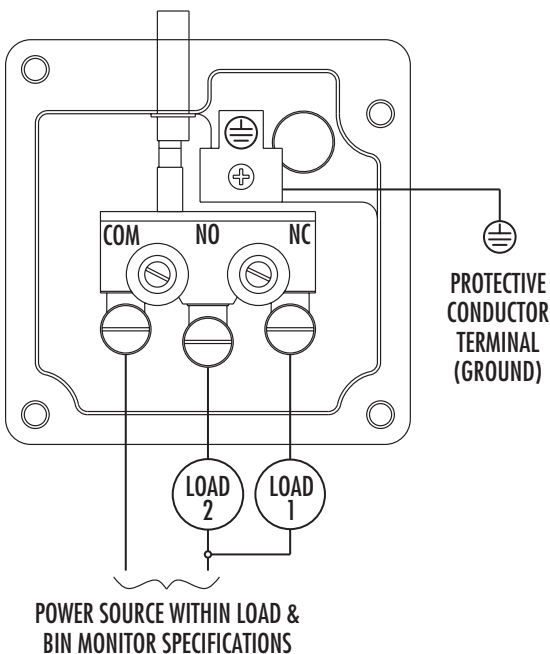

### WARNING

During these load tests be prepared to quickly shut off material feed and electrical power.

**NOTE:** The covers are removed during these tests so use extreme caution.

### MOTOR, DRIVE & BELT TRACKING

### CAUTION

Both mounted and unmounted drives are shipped without oil. Be sure to fill before start up.

Mount the motor and drive. Fill the drive with the proper oil. This is the best time to test the belt tracking while the troughs are fully open and the belt is completely visible. Tighten the tail section to put enough tension on the belt to allow the head pulley to start driving it. Listen for any catching of the splice protectors. Problem areas must be corrected at this time. The suspect areas will usually be improper UHMW connections. If the belt rides to the left, tighten the left takeup screw to move it towards the center. The head bearings can be shimmed if needed but is seldom necessary.

### **IMPORTANT**

*Measure the takeups to see that they are equally extended. The tail bearings may be shimmed so that the belt is centered when the takeups are equal. This is important so that the telescope does not bind when the belt is running on center.*

Once the belt is running true at the head and tail, check along the full length of the conveyor to see that it remains centered. Each spool is adjustable but it is uncommon that they would ever need adjustment. The entire unloaded belt should now run true.

### TEST AND FINISHING

While the conveyor is still open, test the conveyor for capacity using each inlet and observe that the belt stays centered. Start with a light load and gradually increase it to maximum capacity.

After the tests are completed attach the covers with the clamps provided.

The tail shaft is drilled and tapped for the attachment of a user supplied rotation detector.

### CAUTION

Hot bearing detection, plug switches or other specified warning and safety equipment should also be installed if required.

**OPERATION/MAINTENANCE**

The conveyor should operate with very little noise.

 **CAUTION** 

Checking for proper tension should be done every day the conveyor is used.

**Drives**

Follow the manufacturers directions for drive maintenance.

**Bearings**

Bearings have been greased at the factory and are ready to run. When establishing a relubrication schedule, note that a small amount of grease at frequent intervals is preferable to a large amount at infrequent intervals. The schedule is unique for each installation and must be determined by experienced maintenance personnel. Frequency and type of lubrication depends on operating conditions, environment, speed and loads. In cases of severe duty operation, it may be necessary to contact the bearing manufacturers for help in determining the schedule

Generally, low speed bearings (under 250 RPM) should be lubricated by slowly pumping grease into the bearing, while it is rotating, until a thin bead forms at the seal, purging contaminants from the bearing. Bearings should then be greased as often as necessary (daily if required) to maintain a slight leakage at the seals. Normal temperature and a slight showing of grease at the seals indicate proper lubrication.

**TROUBLE SHOOTING**

 **WARNING** 

Be sure to lockout/tagout before doing any maintenance or troubleshooting.

**Tail section plugging:**

1. Make sure flow into the inlet is even and is directed towards discharge.
2. Inlet should be located over a spool. If not sagging may occur causing excess spillage
3. Check skirting and make sure it is in contact with the belt and they are aligned with one another
4. Speed of reloader may be too slow to work

**Not tracking:**

1. Adjust head bearings using jack bolts and shims
2. Adjust tail take-up rods making sure to not over tension belt.
3. Trough alignment should be straight and level, no twists. If the belt has any twist, it may be corrected by adjusting the idler spools. Simply loosen the nuts at the top and bottom of the spool support channels, set the spool as needed, then tighten the nuts.
4. Check head lagging to make sure it is in good condition and not worn. Look for crown on head & tail pulley, 1/8" crown per 12" of pulley width.



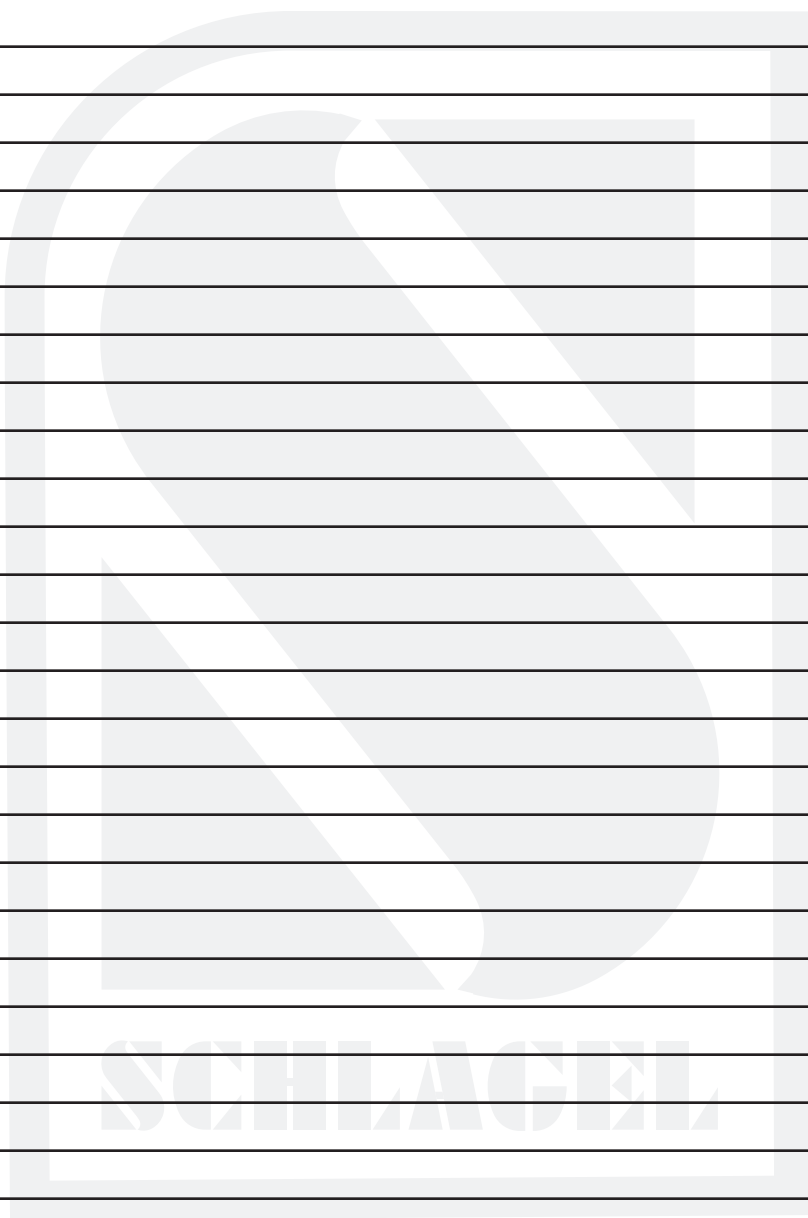



**Please contact our service department for help with any concerns or questions about your EZ-Roll Conveyor.**

**SCHLAGEL**

491 North Emerson Street • Cambridge MN 55008-1316 U.S.A.  
Toll Free (800) 328-8002      FAX (763) 689-5310  
Local / International (763) 689-5991    EMAIL [sales@schlagel.com](mailto:sales@schlagel.com)  
**[www.schlagel.com](http://www.schlagel.com)**