

# R&P VALVES

## Installation and Operation Manual

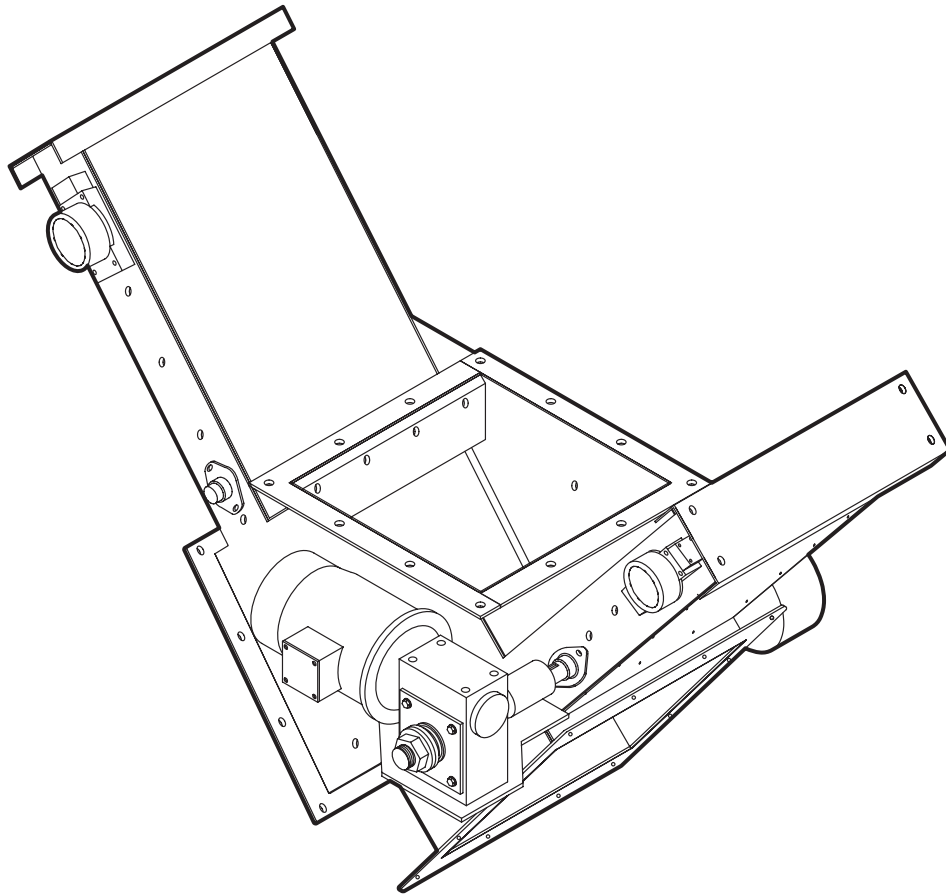

### Manual-Air-Electric Operators

# SCHLAGEL

*Manufacturers of Innovative Materials Handling Equipment since 1957.*

491 North Emerson Street \* Cambridge MN 55008-1316 U.S.A.  
Toll Free (800) 328-8002      FAX (763) 689-5310  
Local / International (763) 689-5991      EMAIL sales@schlagel.com

### GENERAL NOTES

---

- All R&P valves should have the flange joints caulked or gasketed during installation.
- The R&P valve is designed to offer the ultimate dependability in diverting bulk materials. It is NOT a “spouting support system”. Do not attach long spouting runs or misaligned flange joints that would cause deformation of the valve body and subsequent binding or leaking.
- R&P valves are designed to be able to be operated while material is running. They are not meant to shear through the product in a plugged spout condition.
- Do not use our R&P valve with VLF UHMW slide guides in applications where the material is over 200° F. Consult the factory for steel and/or roller bearing guides.

### MANUALLY OPERATED R&P VALVE NOTES

---

- When controlling a cable operated valve from a remote location, be certain that any cable runs have as few changes in direction as possible. Each direction change around a pulley will result in poorer operator “feel” of the valve position. Be especially careful that the cable does not bind against a pulley mounting bracket or some other object. Use a swivel type pulley when necessary.
- Chain wheel operated valves are supplied with a guide to help prevent the chain from coming off the chain wheel. When using a chain wheel, you may wish to use a short length of chain with cable connected to both ends of the chain. This would allow the cable to change directions by going around a pulley.
- Plainly mark the operating controls so that any personnel can tell from a glance if the valve is in the “LEFT” or “RIGHT” position.

### AIR OPERATED R&P VALVE NOTES

---

- Use a clean dry air supply of 100 PSI. It is recommended that some type of air dryer be used to remove moisture rather than a simple bowl type filter.
- If a lubricator is installed in the line then use an air system oil that will not harm the seals used in air cylinders or solenoid valves. There are oils available with anti-freeze ingredients for cold weather areas.  
DO NOT USE EXCESSIVE AMOUNTS OF OIL.
- In cold weather areas, we recommend that electric air solenoid valves be located in a warm control room rather than out by the air cylinder. The freezing that results from moisture in the air line normally happens in the solenoid valve, not the cylinder. Having the solenoid valve in a control room may also eliminate the need for having an explosion proof electrical rating in addition to providing better service access.
- Use adjustable speed controls on large valves that will cycle frequently. This will extend the life of all mechanical components in the valve.
- Use mufflers/filters on the exhausts of any manual or electric solenoid valves to prevent contaminants from getting inside.

## ELECTRIC OPERATED R&P VALVE NOTES

- The standard right-angle gear reducer has been filled with Mobil #1 75W-90 synthetic oil. Do not use anything other than a synthetic oil in cold weather areas. This reducer has an internal slip clutch set at the factory to 120lb-ft. Adjustments to this clutch are rarely required, Figure 1 below, explains the procedure should this be necessary.
- Position indication is accomplished with limit switches. We use the Micro-Switch brand switch #LSXYAB4L. This is a DPDT switch offering a high level of versatility in your control system. The most common synchronized style valve uses two switches, one located at the closed position of each slide. Some customers prefer the redundancy of having four switches in which case the extra switches can be used for position confirmation or alternately can be wired in series with the normal two. The non-synchronized style electric valve always uses four switches so the wiring is identical to that of two standard independent slide gates.
- If your electric operated R&P valve is being used as a splitter or some other application requiring position indication at a location other than fully-open / fully-closed we offer several types of position indicators with output to a physical meter or output in 4-20ma for interface with a PLC control. Contact the factory for details.

Fig. 1

### Hampton Worm Gear Reducer 100:1 Ratio, 56C Frame

This reducer is equipped with a built-in slip clutch. The slip clutch is set at the factory to 120 ft/lbs. In the event the slip clutch needs to be field adjusted, loosen the set screw (using a 5mm allen wrench) and turn the nut as shown using a torque wrench to the desired setting.

The reducer is filled with Mobil #1 75W-90 synthetic lubricant. This provides good service in most normal temperature ranges. As with any gear reducer, the oil should be changed in your normal routine maintenance schedule.

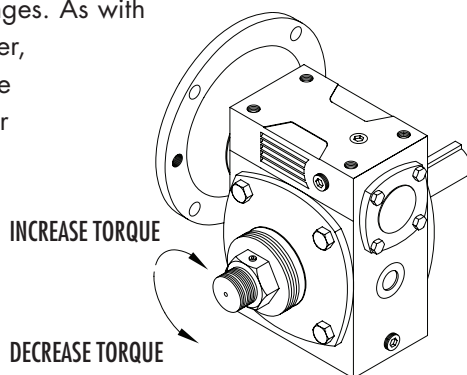

## ROUTINE MAINTENANCE OF YOUR R&P VALVE

- The most common type R&P valve using our VLF style slide guides has very few moving parts and thus requires little routine maintenance. Since most units include some type of lining for demanding applications, regular inspections should be made to make sure that grain has not worn through the housing or slides.
- Synchronized style valves use a chain to connect the two shafts. This chain drive has a built-in tensioning device. See Figure 2 below. Chain tension should be checked regularly, as allowing the chain to get loose could cause the chain to skip teeth on the sprocket resulting in the slides no longer being properly timed.

Fig. 2

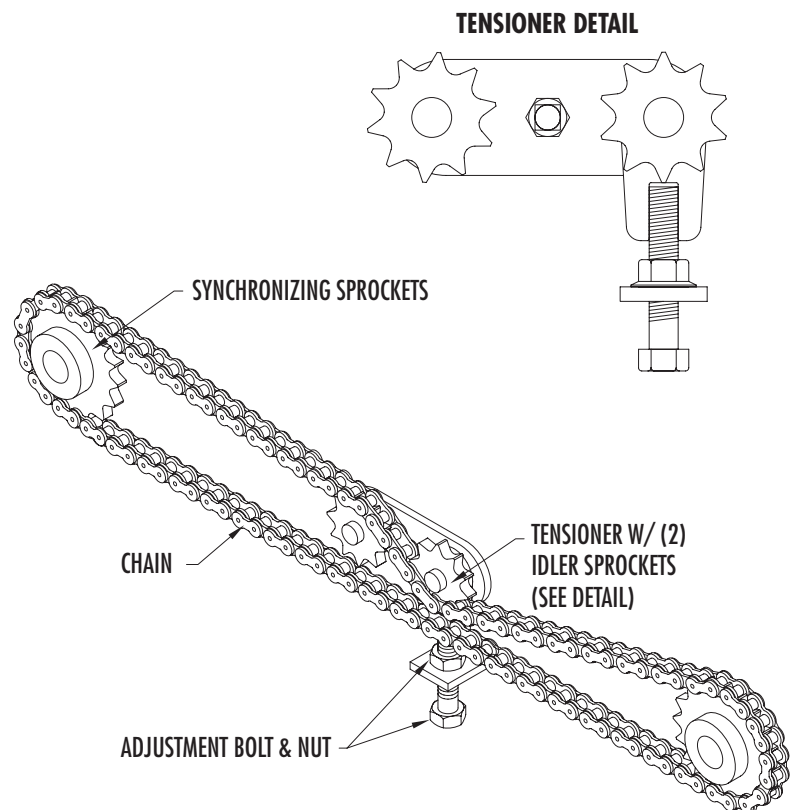

**CAUTION**



The guard is removed for instructional clarity only. Always have the guard installed while operating.

## SECTION 1 - GENERAL

### TYPICAL WIRING DIAGRAM FOR GEARMOTOR DRIVE ON A SYNCHRONIZED STYLE ELECTRIC R&P VALVE THAT HAS ONE MOTOR AND TWO SWITCHES

#### TYPICAL WIRING DIAGRAM

REMOVE INTERNAL JUMPERS 3 TO 6, 5 TO 7.

✕ BREAK FOR MOMENTARY OPERATION

THE LIMIT SWITCHES ARE THE ONLY DEVICES PROVIDED.  
ANY STARTER, PUSH BUTTON CONTROL OR  
INDICATOR LIGHTS ARE TO BE SUPPLIED BY CUSTOMER.

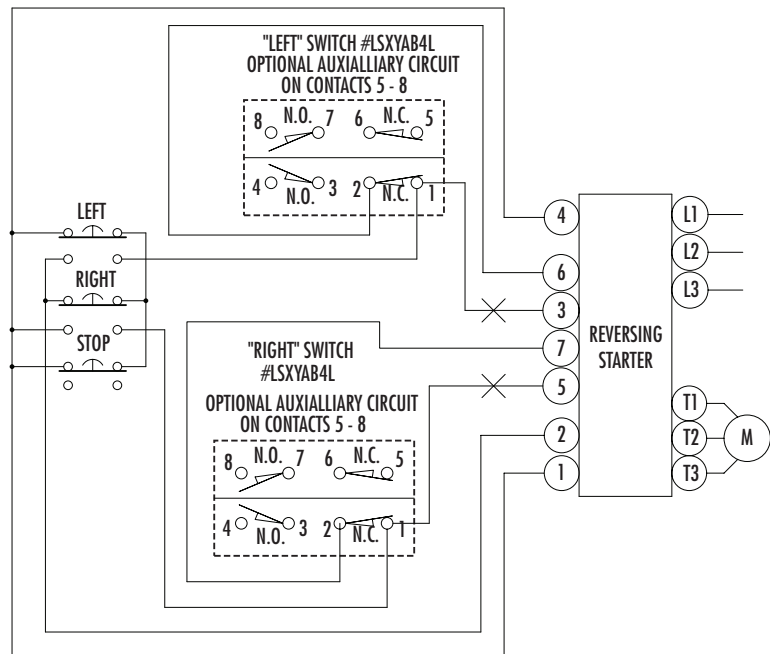

### TYPICAL WIRING DIAGRAM FOR GEARMOTOR DRIVES ON A NON-SYNCHRONIZED STYLE ELECTRIC R&P VALVE THAT HAS TWO MOTORS & 4 SWITCHES (BOTH SIDES OPERATE INDEPENDENTLY SO THERE ARE TWO CIRCUITS LIKE THIS)

#### TYPICAL WIRING DIAGRAM

REMOVE INTERNAL JUMPERS 3 TO 6, 5 TO 7.

✕ BREAK FOR MOMENTARY OPERATION

THE LIMIT SWITCHES ARE THE ONLY DEVICES PROVIDED.  
ANY STARTER, PUSH BUTTON CONTROL OR  
INDICATOR LIGHTS ARE TO BE SUPPLIED BY CUSTOMER.

